

# RG30 Three Axis Rate Gyro 100 deg/sec

## Technical Reference Manual PCB Rev 1.0

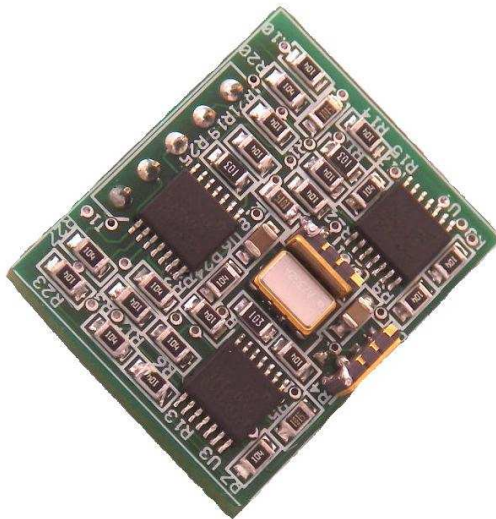

[www.soc-robotics.com](http://www.soc-robotics.com)

## Warranty Statement

SOC Robotics warrants that the Product delivered hereunder shall conform to the applicable SOC Robotics Data Sheet or mutually agreed upon specifications and shall be free from defects in material and workmanship under normal use and service for a period of 30 days from the applicable date of invoice. Products that are “samples”, “design verification units”, and/or “prototypes” are sold “AS IS,” “WITH ALL FAULTS,” and without a warranty. If, during such warranty period, (i) SOC Robotics is notified promptly in writing upon discovery of any defect in the goods, including a detailed description of such defect; (ii) such goods are returned to SOC Robotics, DDP SOC Robotics facility accompanied by SOC Robotics Returned Material Authorization form; and (iii) SOC Robotics examination of such goods discloses to SOC Robotics satisfaction that such goods are defective and such defects are not caused by accident, abuse, misuse, neglect, alteration, improper installation, repair, improper testing, or use contrary to any instructions issued by SOC Robotics. SOC Robotics shall (at its sole option) either repair, replace, or credit Buyer the purchase price of such goods. No goods may be returned to SOC Robotics without SOC Robotics Returned Material Authorization form. Prior to any return of goods by Buyer pursuant to this Section, Buyer shall afford SOC Robotics the opportunity to inspect such goods at Buyer’s location, and any such goods so inspected shall not be returned to SOC Robotics without its prior written consent. SOC Robotics shall return any goods repaired or replaced under this warranty to Buyer transportation prepaid, and reimburse Buyer for the transportation charges paid by Buyer for such goods. The performance of this warranty does not extend the warranty period for any goods beyond that period applicable to the goods originally delivered.

**THE FOREGOING WARRANTY CONSTITUTES SOC ROBOTICS EXCLUSIVE LIABILITY, AND THE EXCLUSIVE REMEDY OF BUYER, FOR ANY BREACH OF ANY WARRANTY OR OTHER NONCONFORMITY OF THE GOODS COVERED BY THIS AGREEMENT. THIS WARRANTY IS EXCLUSIVE, AND IN LIEU OF ALL OTHER WARRANTIES. SOC ROBOTICS MAKES NO OTHER WARRANTIES, EXPRESS, IMPLIED, OR STATUTORY, INCLUDING WITHOUT LIMITATION ANY WARRANTIES OF MERCHANTABILITY OR FITNESS FOR A PARTICULAR PURPOSE. THE SOLE AND EXCLUSIVE REMEDY FOR ANY BREACH OF THIS WARRANTY SHALL BE AS EXPRESSLY PROVIDED HEREIN.**

### Limitation on Liability

Notwithstanding anything to the contrary contained herein, SOC Robotics shall not, under any circumstances, be liable to Buyer or any third parties for consequential, incidental, indirect, exemplary, special, or other damages. SOC Robotics total liability shall not exceed the total amount paid by Buyer or SOC Robotics hereunder. SOC Robotics shall not under any circumstances be liable for excess costs of re-procurement.

### © Copyright 2009. SOC Robotics, Inc. All rights reserved.

SOC Robotics, Inc. makes no warranty for the use of its products, other than those expressly contained in the Company’s standard warranty which is detailed in SOC Robotics Terms and Conditions located on the Company’s web site. The Company assumes no responsibility for any errors which may appear in this document, reserves the right to change devices or specifications detailed herein at any time without notice, and does not make any commitment to update the information contained herein. No licenses to patents or other intellectual property of SOC Robotics are granted by the Company in connection with the sale of SOC Robotics products, expressly or by implication. SOC Robotics products are not authorized for use as critical components in life support devices or systems.

Marks bearing ® and/or ™ are trademarks of SOC Robotics, Inc.  
Terms and product names in this document may be trademarks of others.

1946A-08/00/5M

# Table of Contents

**Warranty Statement**.....2

**1.0 Description**.....4

- 1.1 Features.....4
- 1.2 Introduction.....4
- 1.3 Operation.....5
- 1.4 Software Overview.....6
- 1.5 Specifications.....7
- 1.6 Related Products.....7

**2.0 Electrical and Mechanical Description**.....9

- 2.1 Component Layout.....9
- 2.2 Electrical Specifications.....9
- 2.3 Mechanical Dimensions .....9

**3.0 Circuit Schematics**.....10

## 1.0 Description

### 1.1 Features

- Three axis 100 deg/sec solid state rate gyro
- 0.67mv deg/sec nominal output from sensor
- Instrumentation amplifier boosts signal to 14.9mv deg/sec
- 0.1" header for easy mounting (connector not included)
- 3-3.3V DC operation
- Small form factor (1.00x0.97in)
- Compatible with Wasp/WaspARM/WaspX
- Mounts on WS12 mounting Adapter
- Sample programs included in Wasp Application Code
- Desktop Data Acquisition Device (DAD) for real time display

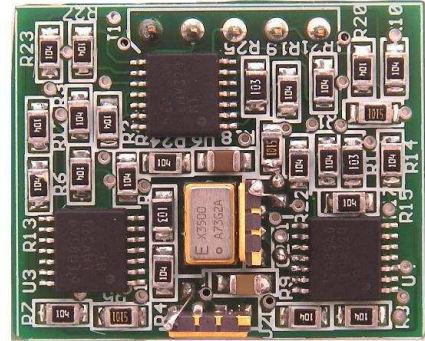

### 1.2 Introduction

The RG30 is a three axis rate gyro that outputs a voltage between 0-3.3VDC volts based on the rotation rate of the device on two axis. Three instrumentation amplifiers on the board amplifies the 0.67mv deg/sec output to a full 0-3.3VDC range. When the device is at rest the nominal output is 1.75V although this value will change as the supply voltage changes.

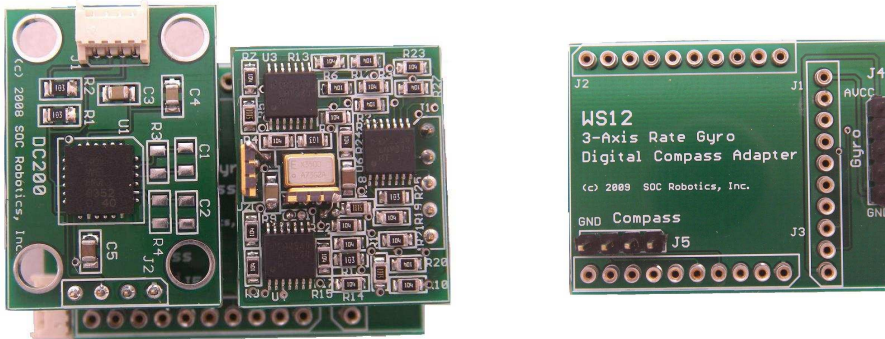

The picture above shows the RG30 attached to the top of a WS12 mounting adapter (shown on the right) that attaches to the Wasp Embedded processor.

### RG30 Pin Assignment

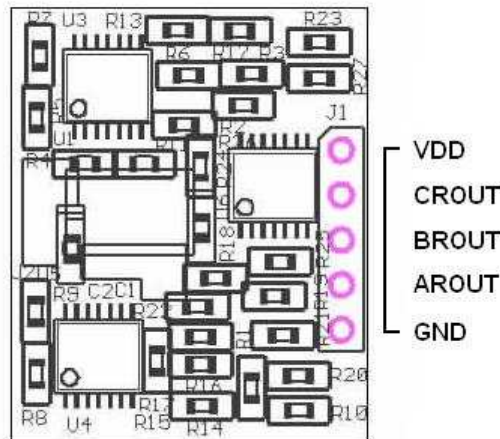

The RG30 output is routed to connector J1 with pin assignments shown above. Note that the board voltage VDD should be within the range 3-3.3VDC. The RG30 is shipped without a connector so you can mount the board as you wish.

### 1.3 Theory of Operation

#### Circuit Description

The RG30 gyro sensor is the Epson Toyocom XV-3500CB 100 deg/sec solid state sensor the output of which is amplified by an LMV324 rail-to-rail operational amplifier with a 21.9 gain stage implemented in an instrumentation amplifier configuration. The schematic below shows the circuit for one axis in the RG20 - both axis are the same.

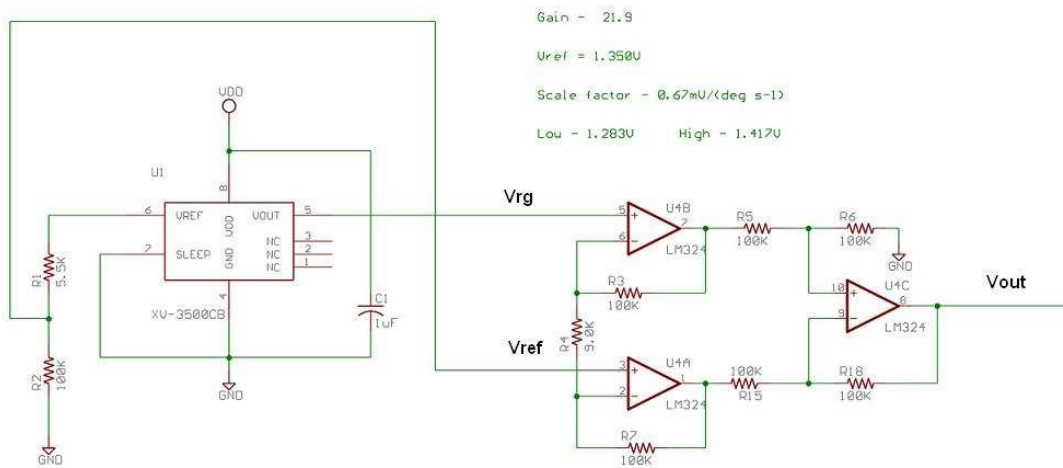

The output of the XV-3500 consists of a reference voltage and rotation signal output. The reference voltage is fixed at 1.350V nominal (this value will vary slightly from part to part). The XV-3500 outputs a rotary signal that varies by  $\pm 67\text{mV}$  full range. This signal is too small to be read with a high degree of precision by most microcontrollers so in order to boost the signal an instrumentation amplifier circuit was added to the design.

The instrumentation amplifier has a fixed gain of 21.9. The reference signal is first reduced from 1.350V to approximately 1.275V by the resistive divider R1, R2. The new reference voltage is feed into the bottom leg of the amplifier. The rotary output signal is fed into the top leg of the instrumentation amplifier. The output of the instrumentation amplifier is given by:

$$V_{out} = 1 + 2R3/R4(V_{rg}-V_{ref})$$

Where  $V_{rg}$  is the rotary signal output and  $V_{ref}$  is the new 1.275V signal. The no rotary output is nominally 1.75volts and any rotation clockwise or counter clockwise will increase or decrease this value at the rate of  $14.7\text{mV deg/sec}$ .

Due to inherent amplifier offsets, sensor reference voltage offsets and the precision of the resistors in the amplifier section the nominal no rotation output will vary slightly from board to board. The next section describes how to compensate for this offset.

If the board is run at a voltage other than 3.3V then the nominal output will be skewed due to the fixed output of the reference signal. Keep this in mind if you run the board at other voltages.

**Polarity of Rotation**

The RG30 has three rate gyros – one parallel to the surface of the PCB, one 90 degrees to the surface and aligned parallel to the connector and the third 90 degrees to the other vertically mounted gyro. Clockwise rotation with respect to the top of the gyro sensor increases signal output while counter clockwise rotation reduces signal output.

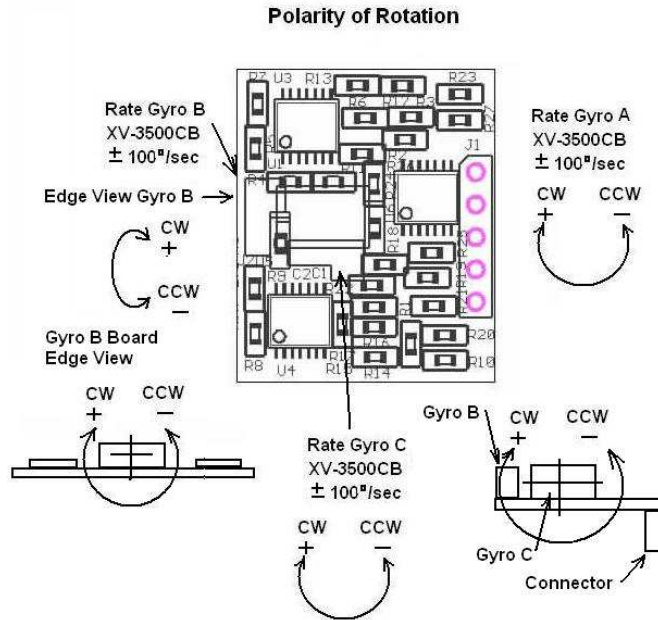

The nominal output signal of the XV-3500CB gyro sensor is 0.67mvolt per degree per second. Maximum output is 67mvolt above or below the nominal no rotation output of 1.350V. The output signal is shifted and amplified to increase the absolute value of the signal. The nominal no rotation output will vary slightly from board to board.

**Calibration**

Although precision resistors are used in the instrumentation amplifier section there are offsets in the op amp that shift the no rotation nominal output from board to board so a calibration step should be performed. To calibrate the RG30 measure the output at no rotation – this is the default output of the device. The gain of the amplifier is fixed at 21.9 so with a sensor output of 0.67mv deg/sec the nominal amplified output is +14.7mv deg/sec.

**1.4 Software Overview**

A sample application (with full source code) that configures the A/D in a Wasp (Atmega644) and outputs the rate gyro readings to the UART is available for download from our web site. A desktop GUI application called DAD is also available to display gyro output in real time in a graph is also available for download.



**1.5 Specifications**

The RG30 uses three Epson Toyocom XV-3500CB solid state rate gyro amplified with a LMV324 op amp in a instrumentation amplifier configuration. The op amp gain is fixed at 21.9 and the nominal no rotation output is shifted to approximately 1.75VDC.

Parameter	Value
Power Source	3.0V-+0.3VDC
Temperature Rnge	-20 to +80 deg C
Number of axis	3
Scale Factor	0.67mv deg/sec
Gain	21.9
Rate Range	-+100 deg/sec
Phase Delay	4 deg @ 20Hz
Frequency Response	200Hz (90 deg delay)
Power Consumption	5.9ma

**1.6 Related Products**

The RG30 is compatible with a number of related products. The WS12 is a carrier that a RG30 attaches to. The WS12 in turn attaches to either a Wasp, WaspARM or WaspX embedded data acquisition processor.

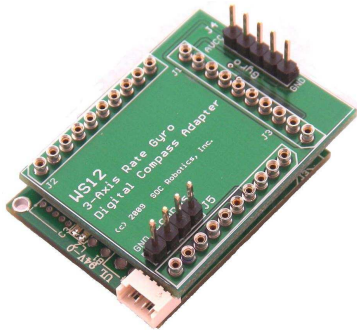

WS12 on Wasp

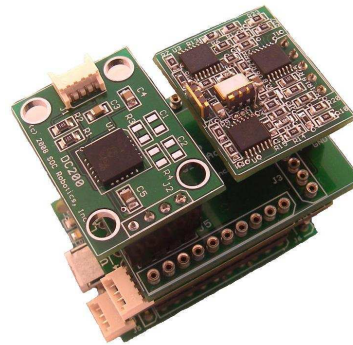

RG30 on WS12 on Wasp and USB10

The Wasp family of products are small AVR and ARM7 based processors that can be programmed by the user to perform data acquisition tasks or using a sample data acquisition program can be turned into a real time data logger. By combining the Wasp with a USB10 a complete data acquisition system that communicates with the desktop via USB becomes possible.

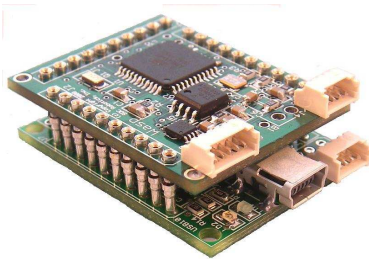

Wasp on USB10

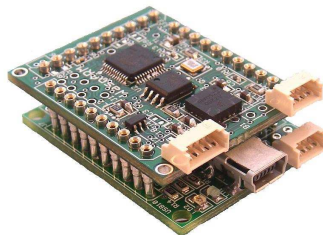

WaspARM on USB10

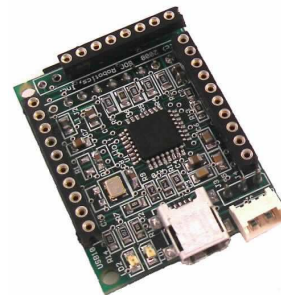

USB10

The RG10 is a single axis rate gyro while the RG20 is a dual axis rate gyro.



RG10

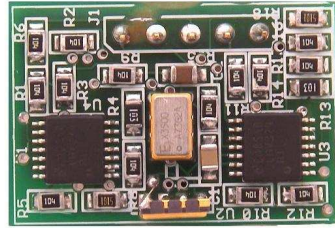

RG20



## 2.0 Electrical and Mechanical Description

### 2.1 Component Layout

Components are mounted on one side of the board.

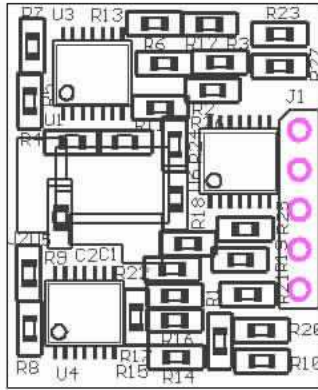

### 2.2 Electrical Specifications

#### Electrical

Input power: 3.3VDC @ 6ma

#### Mechanical

Dimensions: 1.00x0.97 in

Weight: 8 grams

### 2.3 Mechanical Dimensions

Board dimensions are stated in inches.

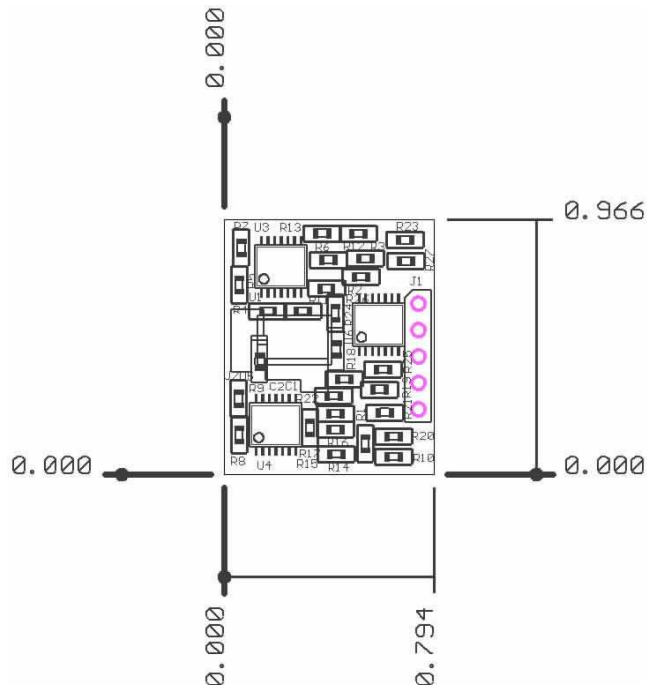

### 3.0 RG30 Circuit Schematics

(c) Copyright 2008. SOC Robotics, Inc. All rights reserved.

3 Axis Rate Gyro

RG30

PCB Rev. 1.0

SOC Robotics, Inc. Vancouver, BC	
TITLE: RateGyro3	
Document Number: 20080610	REV: A
Date: 6/25/2009 04:41:15p	Sheet: 1/2

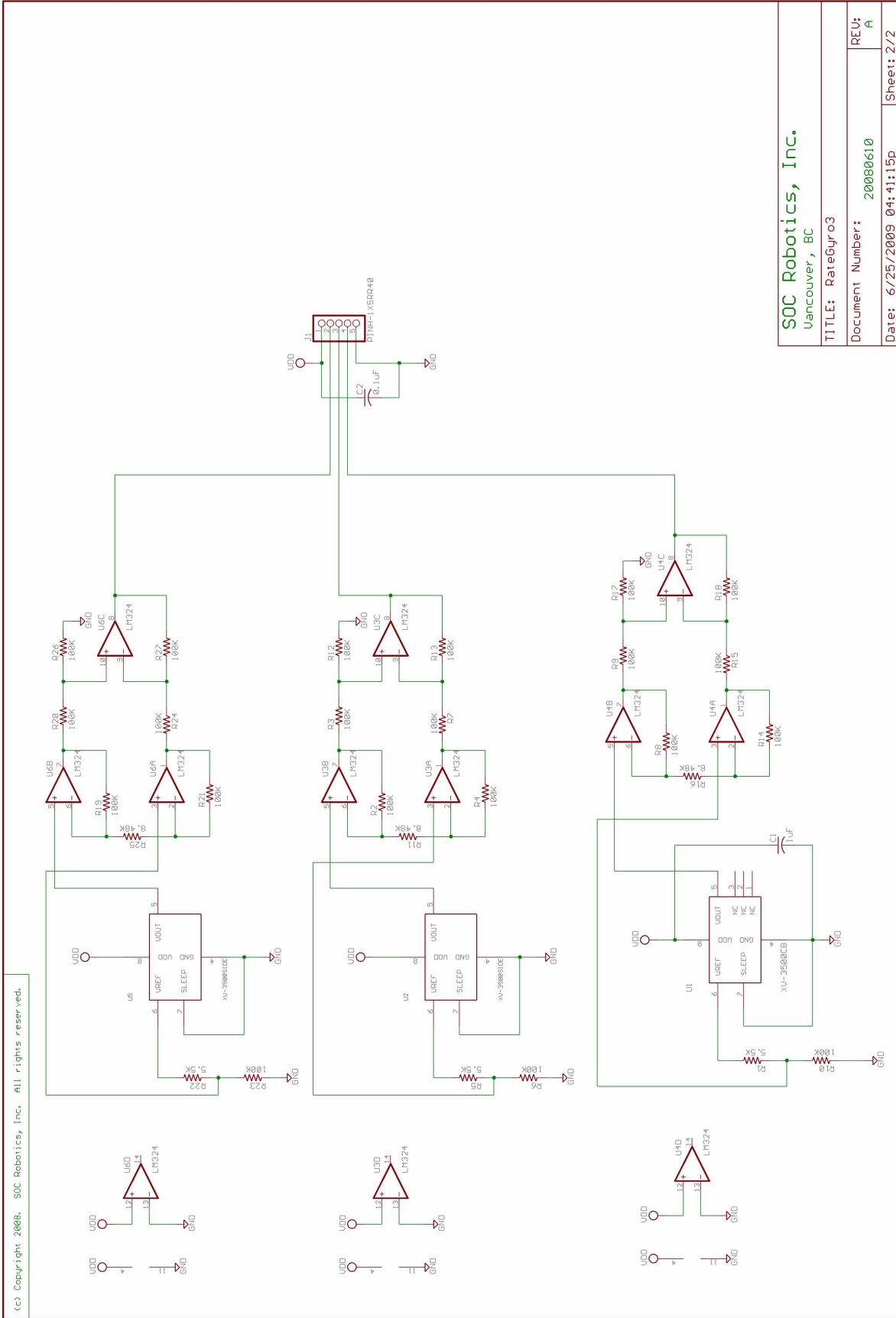

SOC Robotics, Inc.  
 Vancouver, BC  
 TITLE: RateGyro03  
 Document Number: 20080610  
 Date: 6/25/2009 04:41:15p  
 Sheet: 2/2

(c) Copyright 2008, SOC Robotics, Inc. All rights reserved.

**Notes:**