

# TM421 TWI/I2C 4Channel Cross Connect

## Technical Reference Guide

PCB Rev 1.0



[www.soc-robotics.com](http://www.soc-robotics.com)

**Overview**

The TM421 is a TWI I2C 4 channel cross connect that hard connects four TWI I2C buses together. The TM421 has a four pin header that can be used to monitor voltage and the state of the SDA and SCL lines.

**TM421 Pin Assignments**

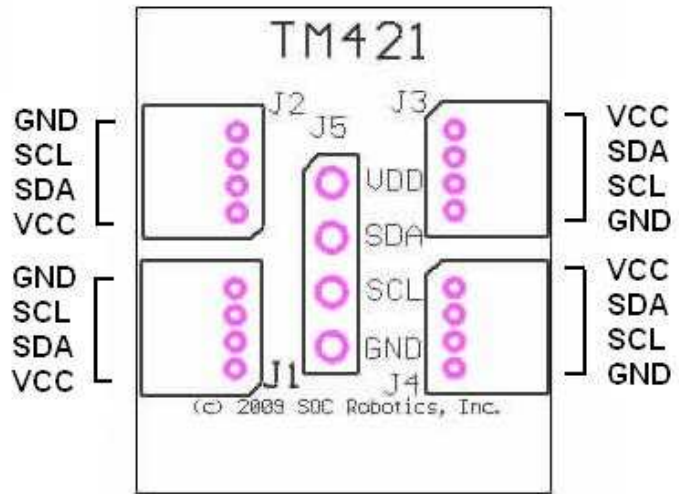
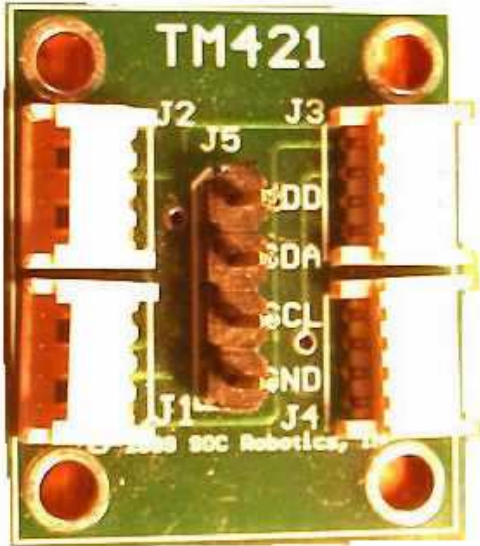

Dimensions in inches.

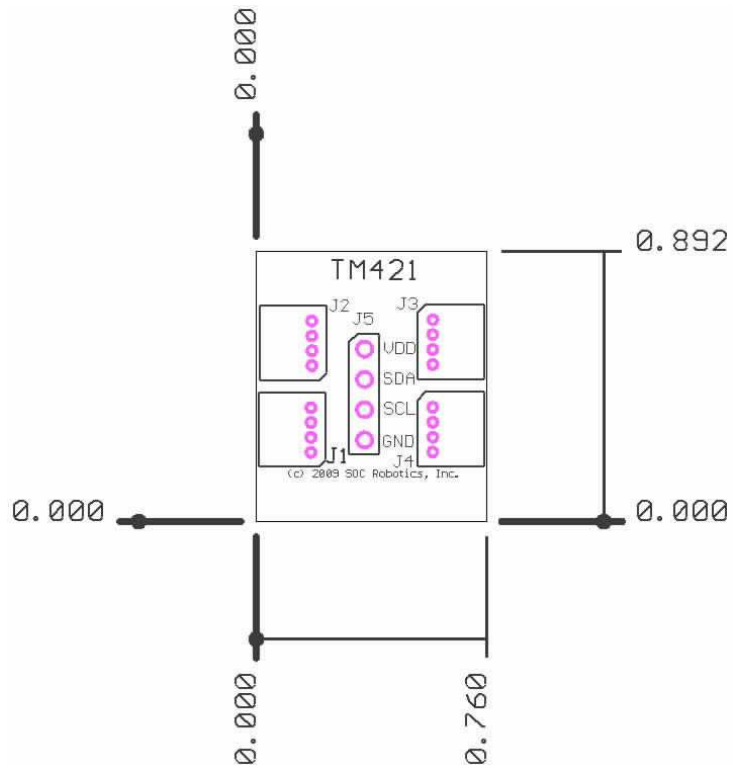

## TM421 Circuit Schematic

(c) Copyright 2008. SOC Robotics, Inc. All rights reserved.

TWI 4 TO 1 Expansion

TM421

PCB Rev. 1.0

SOC Robotics, Inc.  
Vancouver, BC

TITLE: TWI 421

Document Number: 20080610

REV: A

Date: 5/26/2009 01:11:27p

Sheet: 1/2

(c) Copyright 2008. SOC Robotics, Inc. All rights reserved.

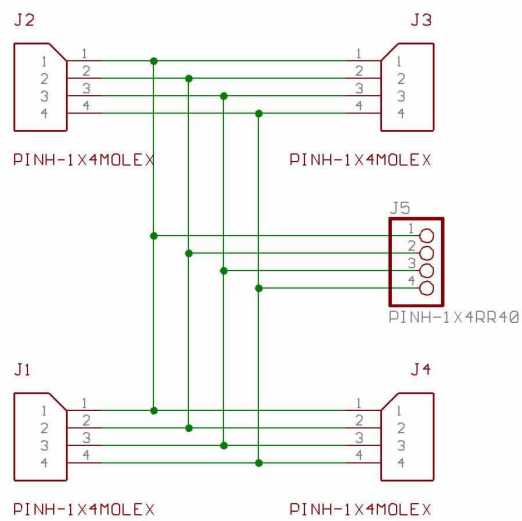

<p>SOC Robotics, Inc. Vancouver, BC</p>	
<p>TITLE: TWI 421</p>	
<p>Document Number: 20080610</p>	<p>REV: A</p>
<p>Date: 5/26/2009 01:11:27p</p>	<p>Sheet: 2/2</p>